

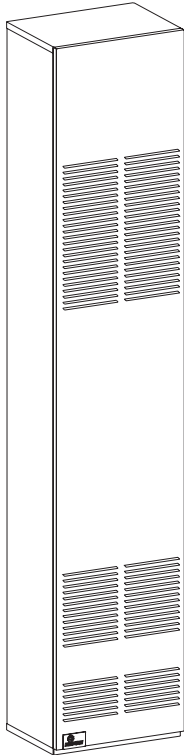

# INSTALLATION INSTRUCTIONS AND OWNER'S MANUAL



## FAN TYPE DIRECT VENT WALL FURNACE

MODEL  
DVC-35-1SPP  
DVC-35-1IP



**Installer:** Leave this manual with the appliance.  
**Consumer:** Retain this manual for future reference.

This appliance may be installed in an aftermarket, permanently located manufactured home (USA only) or mobile home, where not prohibited by state or local codes.  
This appliance is only for use with the type of gas indicated on the rating plate. This appliance is not convertible for use with other gases, unless a certified kit is used.

**WARNING:** If not installed, operated and maintained in accordance with the manufacturer's instructions, this product could expose you to substances in fuel or from fuel combustion which can cause death or serious illness.

**WARNING:** If the information in these instructions are not followed exactly, a fire or explosion may result causing property damage, personal injury or loss of life.

- Do not store or use gasoline or other flammable vapors and liquids in the vicinity of this or any other appliance.
- **WHAT TO DO IF YOU SMELL GAS**
  - Do not try to light any appliance.
  - Do not touch any electrical switch; do not use any phone in your building.
  - Immediately call your gas supplier from a neighbor's phone. Follow the gas supplier's instructions.
  - If you cannot reach your gas supplier, call the fire department.
- Installation and service must be performed by a qualified installer, service agency or the gas supplier.

# TABLE OF CONTENTS

SECTION	PAGE
Important Safety Information.....	3
Safety Information for Users of LP Gas.....	4
Requirements for Massachusetts.....	5
Introduction.....	6
Specifications.....	6
Gas Supply.....	7-8
Clearances.....	8
Installation Instructions.....	9-11
DVC-35SPP Standing Pilot Lighting Instructions.....	12
DVC-35IP Intermittent Pilot Lighting Instructions.....	13
Pilot Flame Characteristics.....	14
Main Burner Flame Characteristics.....	15
Wiring.....	15-16
Service and Maintenance Suggestions.....	17
DVC-35IP Intermittent Pilot Sequence of Operation.....	18
DVC-35IP Intermittent Pilot System Troubleshooting Sequence.....	19
How to Order Repair Parts.....	20
Parts List.....	20
Parts View.....	21
Service Notes.....	22-23

# IMPORTANT SAFETY INFORMATION

## THIS IS A HEATING APPLIANCE

DO NOT OPERATE THIS APPLIANCE WITHOUT FRONT PANEL INSTALLED.

- Due to high temperatures, the appliance should be located out of traffic and away from furniture and draperies.
- Children and adults should be alerted to the hazards of high surface temperatures and should stay away to avoid burns or clothing ignition.
- Young children should be carefully supervised when they are in the same room as the appliance.
- Clothing or other flammable material should not be placed on or near the appliance.
- Any safety screen or guard removed for servicing an appliance must be replaced prior to operating the appliance.
- Keep burner and control compartment clean.
- Vent cap hot while furnace is in operation.
- Installation and repair should be done by a **QUALIFIED SERVICE PERSON**. The appliance should be inspected before use and at least annually by a qualified service person. More frequent cleaning may be required due to excessive lint from carpeting, bedding materials, etc. It is imperative that control compartments, burners and circulating air passageways of the appliance be kept clean.
- **DO NOT** put anything around the furnace that will obstruct the flow of combustion and ventilation air.
- **DO** keep the appliance area clear and free from combustible material, gasoline and other flammable vapors and liquids.
- **DO** examine venting system periodically and replace damaged parts.
- **DO** make a periodic visual check of pilot and burners. Clean and replace damaged parts.
- **CAUTION:** Pilot hole cover must be kept tightly closed during operation.
- **DO NOT** use this heater if any part has been under water. Immediately call a qualified service technician to inspect the heater and to replace any part of the control system and any gas control which has been under water.

**IMPORTANT:** This furnace has a washable permanent type filter which should be cleaned at least once per year before the heating season. For dirty or high use areas, more frequent cleaning is required.

# SAFETY INFORMATION FOR USERS OF LP-GAS

Propane (LP-Gas) is a flammable gas which can cause fires and explosions. In its natural state, propane is odorless and colorless. You may not know all the following safety precautions which can protect both you and your family from an accident. Read them carefully now, then review them point

by point with the members of your household. Someday, when there may not be a minute to lose, everyone's safety will depend on knowing exactly what to do. If, after reading the following information, you feel you still need more information, please contact your gas supplier.

## LP-GAS WARNING ODOR

If a gas leak happens, you should be able to smell the gas because of the odorant put in the LP-Gas. That's your signal to go into immediate action!

- Do not operate electric switches, light matches, use your phone. Do not do anything that could ignite the gas.
- Get everyone out of the building, vehicle, trailer, or area. Do that IMMEDIATELY.
- Close all gas tank or cylinder supply valves.
- LP-Gas is heavier than air and may settle in low areas such as basements. When you have reason to suspect a gas leak, keep out of basements and other low areas. Stay out until firefighters declare them to be safe.
- Use your neighbor's phone and call a trained LP-Gas service person and the fire department. Even though you may not continue to smell gas, do not turn on the gas again. Do not re-enter the building, vehicle, trailer, or area.
- **Finally**, let the service man and firefighters check for escaped gas. Have them air out the area before you return. Properly trained LP-Gas service people should repair the leak, then check and relight the gas appliance for you.

## NO ODOR DETECTED - ODOR FADE

Some people cannot smell well. Some people cannot smell the odor of the chemical put into the gas. You must find out if you can smell the odorant in propane. Smoking can decrease your ability to smell. Being around an odor for a time can affect your sensitivity or ability to detect that odor. Sometimes, other odors in the area mask the gas odor. People may not smell the gas odor or their minds are on something else. Thinking about smelling a gas odor can make it easier to smell.

The odorant in LP-Gas is colorless, and it can fade under some circumstances. For example, if there is an underground leak, the movement of the gas through soil can filter the odorant. Odorants in LP-Gas are subject to oxidation. This fading can occur

if there is rust inside the storage tank or in iron gas pipes.

The odorant in escaped gas can adsorb or absorb onto or into walls, masonry and other materials and fabrics in a room. That will take some of the odorant out of the gas, reducing its odor intensity.

LP-Gas may stratify in a closed area, and the odor intensity could vary at different levels. Since it is heavier than air, there may be more odor at lower levels. Always be sensitive to the slightest gas odor. If you detect any odor, treat it as a serious leak. Immediately go into action as instructed earlier.

## SOME POINTS TO REMEMBER

- **Learn to recognize the odor of LP-gas.** Your local LP-Gas Dealer can give you a "Scratch and Sniff" pamphlet. Use it to find out what the propane odor smells like. If you suspect that your LP-Gas has a weak or abnormal odor, call your LP-Gas Dealer.
- If you are not qualified, do not light pilot lights, perform service, or make adjustments to appliances on the LP-Gas system. If you are qualified, consciously think about the odor of LP-Gas prior to and while lighting pilot lights or performing service or making adjustments.
- Sometimes a basement or a closed-up house has a musty smell that can cover up the LP-Gas odor. Do not try to light pilot lights, perform service, or make adjustments in an area where the conditions are such that you may not detect the odor if there has been a leak of LP-Gas.
- Odor fade, due to oxidation by rust or adsorption on walls of new cylinders and tanks, is possible. Therefore, people should be particularly alert and careful when new tanks or cylinders are placed in service. Odor fade can occur in new tanks, or reinstalled old tanks, if they are filled and allowed to set too long before refilling. Cylinders and tanks which have been out of service for a time may develop internal rust which will cause odor fade. If such conditions are suspected to exist, a periodic sniff test of the gas is advisable. **If you have any question about the gas odor, call your LP-Gas Dealer. Aperiodic sniff test of the LP-Gas is a good safety measure under any condition.**
- If, at any time, you do not smell the LP-Gas odorant and you think you should, assume you have a leak. Then take the same immediate action recommended above for the occasion when you do detect the odorized LP-Gas.
- If you experience a complete "gas out" (the container is under no vapor pressure), turn the tank valve off immediately. If the container valve is left on, the container may draw in some air through openings such as pilot light orifices. If this occurs, some new internal rusting could occur. If the valve is left open, then treat the container as a new tank. Always be sure your container is under vapor pressure by turning it off at the container before it goes completely empty or having it refilled before it is completely empty.

# REQUIREMENTS FOR MASSACHUSETTS

For all side wall horizontally vented gas fueled equipment installed in every dwelling, building or structure used in whole or in part for residential purposes, including those owned or operated by the Commonwealth and where the side wall exhaust vent termination is less than seven (7) feet above finished grade in the area of the venting, including but not limited to decks and porches, the following requirements shall be satisfied:

1. **INSTALLATION OF CARBON MONOXIDE DETECTORS.** At the time of installation of the side wall horizontal vented gas fueled equipment, the installing plumber or gasfitter shall observe that a hard wired carbon monoxide detector with an alarm and battery back-up is installed on the floor level where the gas equipment is to be installed. In addition, the installing plumber or gasfitter shall observe that a battery operated or hard wired carbon monoxide detector with an alarm is installed on each additional level of the dwelling, building or structure served by the side wall horizontal vented gas fueled equipment. It shall be the responsibility of the property owner to secure the services of qualified licensed professionals for the installation of hard wired carbon monoxide detectors
  - a. In the event that the side wall horizontally vented gas fueled equipment is installed in a crawl space or an attic, the hard wired carbon monoxide detector with alarm and battery back-up may be installed on the next adjacent floor level.
  - b. In the event that the requirements of this subdivision can not be met at the time of completion of installation, the owner shall have a period of thirty (30) days to comply with the above requirements; provided, however, that during said thirty (30) day period, a battery operated carbon monoxide detector with an alarm shall be installed.
2. **APPROVED CARBON MONOXIDE DETECTORS.** Each carbon monoxide detector as required in accordance with the above provisions shall comply with NFPA 720 and be ANSI/UL 2034 listed and IAS certified.
3. **SIGNAGE.** A metal or plastic identification plate shall be permanently mounted to the exterior of the building at a minimum height of eight (8) feet above grade directly in line with the exhaust vent terminal for the horizontally vented gas fueled heating appliance or equipment. The sign shall read, in print size no less than one-half (1/2) inch in size, **“GAS VENT DIRECTLY BELOW. KEEP CLEAR OF ALL OBSTRUCTIONS”**.
4. **INSPECTION.** The state or local gas inspector of the side wall horizontally vented gas fueled equipment shall not approve the installation unless, upon inspection, the inspector observes carbon monoxide detectors and signage installed in accordance with the provisions of 248 CMR 5.08(2)(a) 1 through 4.
  - (b) **EXEMPTIONS:** The following equipment is exempt from 248 CMR 5.08(2)(a)1 through 4:
    1. The equipment listed in Chapter 10 entitled “Equipment Not Required To Be Vented” in the most current edition of NFPA 54 as adopted by the Board; and
    2. Product Approved side wall horizontally vented gas fueled equipment installed in a room or structure separate from the dwelling, building or structure used in whole or in part for residential purposes.
  - (c) **MANUFACTURER REQUIREMENTS - GAS EQUIPMENT VENTING SYSTEM PROVIDED.** When the manufacturer of Product Approved side wall horizontally vented gas equipment provides a venting system design or venting system components with the equipment, the instructions provided by the manufacturer for installation of the equipment and the venting system shall include:
    1. Detailed instructions for the installation of the venting system design or the venting system components; and
    2. A complete parts list for the venting system design or venting system.
  - (e) A copy of all installation instructions for all Product Approved side wall horizontally vented gas fueled equipment, all venting instructions, all parts lists for venting instructions, and/or all venting design instructions shall remain with the appliance or equipment at the completion of the installation.

# INTRODUCTION

## Introduction

Always consult your local Building Department regarding regulations, codes or ordinances which apply to the installation of a direct vent wall furnace.

## Instructions to Installer.

1. Installer must leave instruction manual with owner after installation.
2. Installer must have owner fill out and mail warranty card supplied with furnace.
3. Installer should show owner how to start and operate furnace and thermostat.

### Warning:

**Any change to this furnace or its control can be dangerous. This is a heating appliance and any panel, door, or guard removed for servicing an appliance must be replaced prior to operating the appliance.**

## General Information

This furnace is design certified in accordance with American National Standard/CSA Standard Z21.86b-2002 and CSA 2.32b-2002 by the Canadian Standards Association, as a fan type direct vent wall furnace to be installed according to these instructions.

**Any alteration of the original design, installed other than as shown in these instructions or use with a type of gas not shown on the rating plate is the responsibility of the person and company making the change.**

## Important

All correspondence should refer to complete Model No., Serial No., and type of gas.

**Notice:** During initial firing of this unit, its paint will bake out and smoke will occur. To prevent triggering of smoke alarms, ventilate the room in which the unit is installed.

## Installation on Rugs and Tile

If this appliance is installed directly on carpeting, tile or other combustible material other than wood flooring, the appliance shall be installed on a metal or wood panel extending the full width and depth of the appliance.

The base referred to above does not mean the fire-proof base as used on wood stoves. The protection is for rugs that are extremely thick and light colored tile.

## Installation in Residential Garages

Gas utilization equipment in residential garages shall be installed so that all burners and burner ignition devices are located not less than 18" above the floor.

Such equipment shall be located, or protected, so it is not subject to physical damage by a moving vehicle.

## Qualified Installing Agency

Installation and replacement of gas piping, gas utilization equipment or accessories and repair and servicing of equipment shall be performed only by a qualified agency. The term "qualified agency" means any individual, firm, corporation or company which either in person or through a representative is engaged in and is responsible for (a) the installation or replacement of gas piping or (b) the connection, installation, repair or servicing of equipment, who is experienced in such work, familiar with all precautions required and has complied with all the requirements of the authority having jurisdiction.

**State of Massachusetts:** The installation must be made by a licensed plumber or gas fitter in the Commonwealth of Massachusetts.

The installation must conform with local codes or, in the absence of local codes, with the *National Fuel Gas Code ANSI Z223.1/NFPA 54\* Natural Gas and Propane Installation Code, CSA B149.1.*

\* Available from the American National Standards Institute, Inc., 11 West 42nd St., New York, N.Y. 10036

## High Altitudes

For altitudes/elevations above 2,000 feet, input ratings should be reduced at the rate of 4 percent for each 1,000 feet above sea level. For Canadian high altitude applications, this appliance is suitable for installation at elevations between 0 feet and 4,500 feet without change.

## Piezo Pilot Ignitor Instructions

Depressing the red button completely causes a spark to occur at the pilot. This is a substitute for a match which requires opening the pilot hole cover.

To light the pilot, it is important that the electrode be 1/8" from the thermocouple. The spark must occur at the point the burner flame hits the thermocouple. The end of the electrode will be red hot with the pilot on.

On a new installation with air in the gas line, it is suggested that a match be used. The match will light the pilot faster than the piezo under this condition.

# SPECIFICATIONS

Model	DVC-35SPP	DVC-35IP
Input BTU/HR	35,000	35,000
Height	72 1/2"	72 1/2"
Width	14 1/8"	14 1/8"
Depth	10 3/8"	10 3/8"
Gas Inlet	1/2" Pipe	1/2" Pipe
CFM	275	275
<b>Accessories</b>		
SOR-1	Register, Side Outlet	
SOK-1	Side Outlet Kit, 10" (25.4cm) Boot Assembly with Register	
*DV-822	Vinyl Siding Vent Kit	
*DV-822, Vinyl siding vent kit, adds 3" to wall depth. You must include the three (3) additional inches for <b>TOTAL</b> wall depth when ordering a vent kit.		



# GAS SUPPLY

## Locating Gas Supply

The gas line can enter the unit either through the floor or outside wall. The gas line opening should be made at this time. Location of the opening will be determined by the position of floor joists and the valve and union used for servicing.

**Recommended Gas Pipe Diameter**

Pipe Length (Feet)	Schedule 40 Pipe Inside Diameter		Tubing, Type L Outside Diameter	
	Nat.	L.P.	Nat.	L.P.
0-10	1/2" 1.3 cm	3/8" 1.0 cm	1/2" 1.3 cm	3/8" 1.0 cm
10-40	1/2" 1.3 cm	1/2" 1.3 cm	5/8" 1.6 cm	1/2" 1.3 cm
40-100	1/2" 1.3 cm	1/2" 1.3 cm	3/4" 1.9 cm	1/2" 1.3 cm
100-150	3/4" 1.9 cm	1/2" 1.3 cm	7/8" 2.2 cm	3/4" 1.9 cm

**Note:** Never Use plastic pipe. Check to confirm whether your local codes allow copper tubing or galvanized.

**Note:** Since some municipalities have additional local codes, it is always best to consult your local authority and installation code.

The use of the following gas connectors is recommended:

- ANS Z21.24 Appliance Connectors of Corrugated Metal Tubing and Fittings
- ANS Z21.45 Assembled Flexible Appliance Connectors of Other Than All-Metal Construction

The above connectors may be used if acceptable by the authority having jurisdiction. The state of Massachusetts requires that a flexible appliance connector cannot exceed three feet in length.

### FLEXIBLE GAS LINE CONNECTION

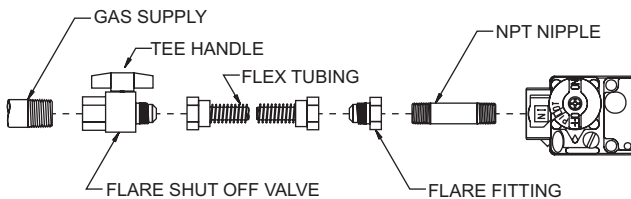

### RIGID GAS LINE CONNECTION

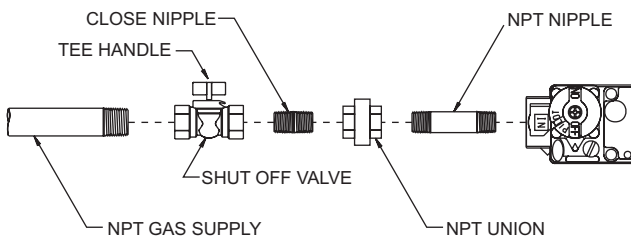

**Figure 1**

Consult the current National Fuel Gas Code, ANSI Z223.1 CAN/CGA-B149 (.1 or .2) installation code.

## Installing a New Main Gas Cock

Each appliance should have its own manual gas cock.

A manual main gas cock should be located in the vicinity of the unit. Where none exists, or where its size or location is not adequate, contact your local authorized installer for installation or relocation.

Compounds used on threaded joints of gas piping shall be resistant to the action of liquefied petroleum gases. The gas lines must be checked for leaks by the installer. This should be done with a soap solution watching for bubbles on all exposed connections, and if unexposed, a pressure test should be made.

**Never use and exposed flame to check for leaks. Appliance must be disconnected from piping at inlet of control valve and pipe capped or plugged for pressure test. Never pressure test with appliance connected; control valve will sustain damage!**

A gas valve and ground joint union should be installed in the gas line upstream of the gas control to aid in servicing. It is required by the National Fuel Gas Code that a drip line be installed near the gas inlet. This should consist of a vertical length of pipe tee connected into the gas line that is capped on the bottom in which condensation and foreign particles may collect.

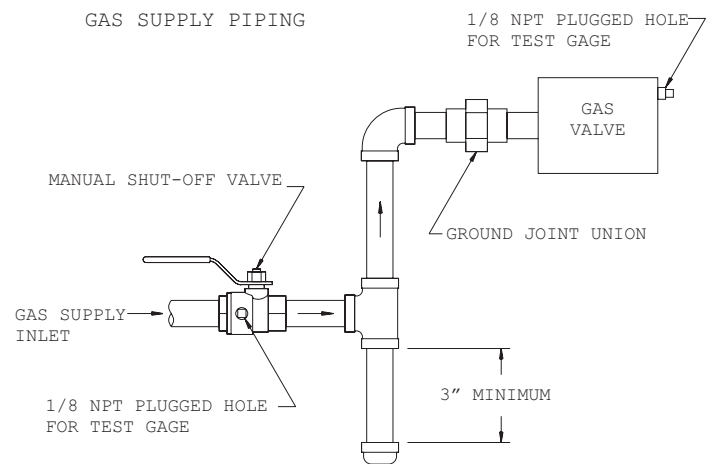

**Figure 2**  
**Method of Installing a Tee Fitting Sediment Trap**

## Pressure Testing of the Gas Supply System

1. To check the inlet pressure to the gas valve, a 1/8" N.P.T. plugged tapping, accessible for test gauge connection, must be placed immediately upstream of the gas supply connection to the appliance.
2. The appliance and its individual shutoff valve must be disconnected from the gas supply piping system during any pressure testing of that system at test pressures in excess of 1/2 psig (3.5 kPa).
3. The appliance must be isolated from the gas supply piping system by closing its individual manual shutoff valve during any pressure testing of the gas supply piping system at test pressures equal to or less than 1/2 psig (3.5 kPa)

**Attention!** If one of the above procedures results in pressures in excess of 1/2 psig (14" w.c) (3.5 kPa) on the appliance gas valve, it will result in a hazardous condition.

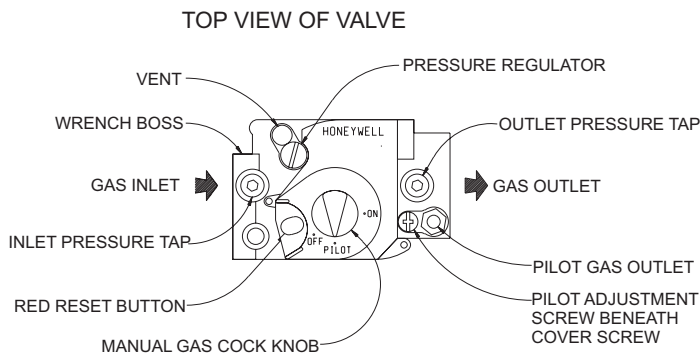

Figure 3

### Checking Manifold Pressure

Both Propane and Natural gas valves have a built-in pressure regulator in the gas valve. Natural gas models will have a manifold pressure of approximately 4.0" w.c. (.996kPa) at the valve outlet with the inlet pressure to the valve from a minimum of 5.0" w.c. (1.245kPa) for the purpose of input adjustment to a maximum of 7.0" w.c. (1.743kPa). Propane gas models will have a manifold pressure approximately 10.0" w.c. (2.49kPa) at the valve outlet with the inlet pressure to the valve from a minimum of 11.0" w.c. (2.739kPa) for the purpose of input adjustment to a maximum of 13.0" w.c. (3.237kPa).

A 1/8" N.P.T. plugged tapping, accessible for test gauge connection, is located on the outlet side of the gas control.

The built-in regulator comes on at approximately 1/4th pressure and full on in 10 seconds.

## CLEARANCES

### Pressure Testing of the Gas Supply System

1. In selecting a location for installation, it is necessary to provide adequate accessibility clearances for servicing and proper installation. A front clearance of 36" (91.4cm) is recommended. Do not block outlet or inlet air openings on the front grill.
2. The DVC-35 minimum wall depth is 3/4" (19mm) and maximum wall depth is 10" (254mm). The maximum wall depth may be extended using the model DV-1190 extended flue kit. The use of tubes not supplied by the manufacturer results in unsatisfactory performance.
3. The DVC-35 can be attached to the wall or recessed into the wall up to 9 1/2" (241mm) in depth but the minimum 3/4" (19mm) vent/air intake system wall depth must be maintained. Example: If furnace is recessed into the wall at a depth of 9 1/2" (241mm), the minimum wall depth must be 10 1/4" (260mm).
4. The wall in which the furnace is recessed has (0) zero clearance to the furnace sides and top.
5. When using side discharge registers, SOR-1 or SOK-1, the furnace cannot be recessed into the wall.
6. Clearance to sidewall or combustible material is 4" (102mm).
7. Ceiling clearance is 4" (201mm).
8. Floor and rear wall clearance is (0) zero inches.
9. Clearance of 18" (457mm) is required to sidewall or combustible material when flush mounted SOR-1, side outlet register is used.
10. The minimum distance from the center of the vent cap to the nearest outside corner or obstruction is 12" (305mm).

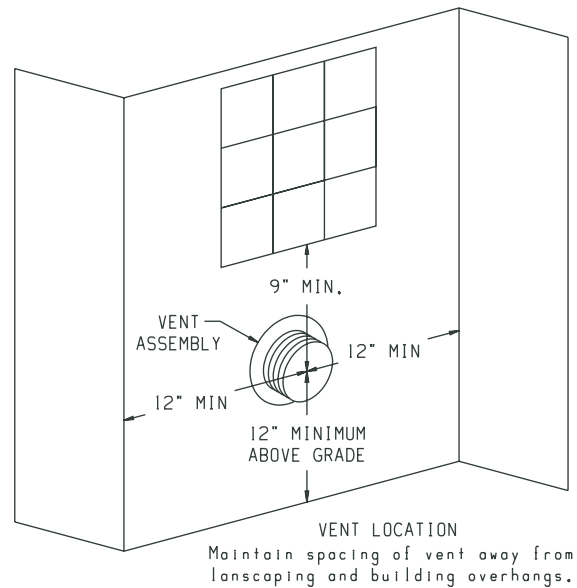

Figure 4

The vent terminal of this direct vent appliance shall be located at least 9" (229mm) from any opening through which flue gases could enter a building. The bottom of the vent terminal and the air intake shall be located at least 12" (305mm) above grade. See vent location, Figure 4.

**WARNING: The nearest point of the vent cap should be a minimum horizontal distance of six (6) feet (1.83m) from any pressure regulator. In case of regulator malfunction, the six (6) feet (1.83m) distance will reduce the chance of gas entering the vent cap.**



# INSTALLATION INSTRUCTIONS

## Locating Wall Opening

The furnace is to be located on an outside wall. Locate wall studs so that wall opening will be located between wall studs. The furnace is 14 1/8" (358mm) in width and can be recessed between standard 16" (406mm) on center wall stud. The wall opening required as shown in Figure 5 is a diameter of 7 1/2" (191mm).

A template is provided in furnace carton for positioning furnace on the wall. Also, refer to Figure 5 and Figure 7 for positioning the furnace on wall and for locating gas line connection.

## Installing Optional Side Outlets

Side outlet register, SOR-1 may be installed on one or both sides of the furnace at the required clearances of 18" (457mm) to adjacent wall or combustible material as shown in Figure 6.

1. Turn "OFF" all electric power to the furnace.
2. Remove the front panel from the furnace.
3. Remove the (2) #8 X 3/8" (9mm) screws that attach the inner shield cover plate to the inner shield.
4. Scribe a line between the four dimples on the outer casing side to form a square.
5. Drill a pilot hole within the scribed square on the outer casing. Remove the sheet metal within the scribed square with a tin snips or comparable tool. Attention! Do not cut the electrical wires located between the outer casing and the inner shield.
6. Insert the 5" x 5" (127mm x 127mm) inner boot through the outer casing. Align the clearance holes on the inner boot with the crew holes on the inner shield. Attach inner boot to inner shield with (2) #8 x 3/8" (9mm) screws removed in Step 3.
7. Place the register over the 5 1/2" (140mm) square opening with the louvers set for the desired direction and mark the mounting holes using the register as a template.
8. Drill (2) 1/8" diameter holes in cabinet side and attach the register with (2) #10 x 1" (25mm) provided screws.
9. Installation of SOR-1 is completed.

**Side outlet kit, SOK-1, 10" (254mm) boot assembly with register, for warm air discharge into an adjoining room may be installed on either side of the furnace at the required clearance of 4" (102mm) to adjacent wall as shown in Figure 6.**

To install SOK-1, please use step 1 through 5 in the SOR-1 instructions for DVC-35 furnaces. Then, use the following Steps to complete the installation of the SOK-1.

1. Using the inner and outer boots as hole templates, mark and drill (4) 1/8" (3mm) diameter holes in the inner shield and (4) 1/8" (3mm) diameter holes in the cabinet side.
2. Locate and cut a 6 3/4" (171mm) square opening through wall.
3. Attach furnace to wall (see Attaching Furnace to Wall).
4. With furnace in place, after checking alignment of side outlet opening in wall and furnace, place the 9 3/8" x 9 3/8" (238mm x 238mm) side outlet wall plate over outer boot, pass the outer boot through the wall and attach side wall plate to furnace side of wall with (2) #10 x 1 1/2" (38mm) provided screws.
5. Attach outer boot to the cabinet side with (4) #8 x 1/4" (6mm) provided screws.
6. Position and attach inner boot to inner shield with (4) #8 x 1/4" (6mm) provided screws.
7. Place the register over the 6 3/4" (171mm) square opening with

- the louvers positioned for the desired discharge direction and mark the mounting holes using the register as a template.
8. Drill (2) 1/8" (3mm) diameter holes in the wall and attach the register with (2) #10 x 1 1/2" (38mm) provided screws.
9. Installation of SOK-1 is completed.

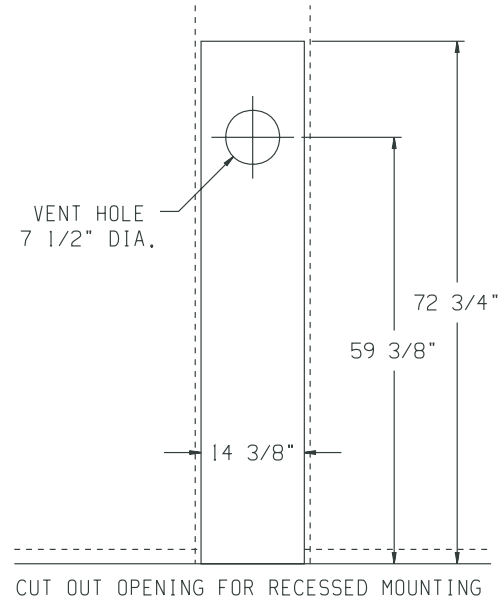

Figure 5

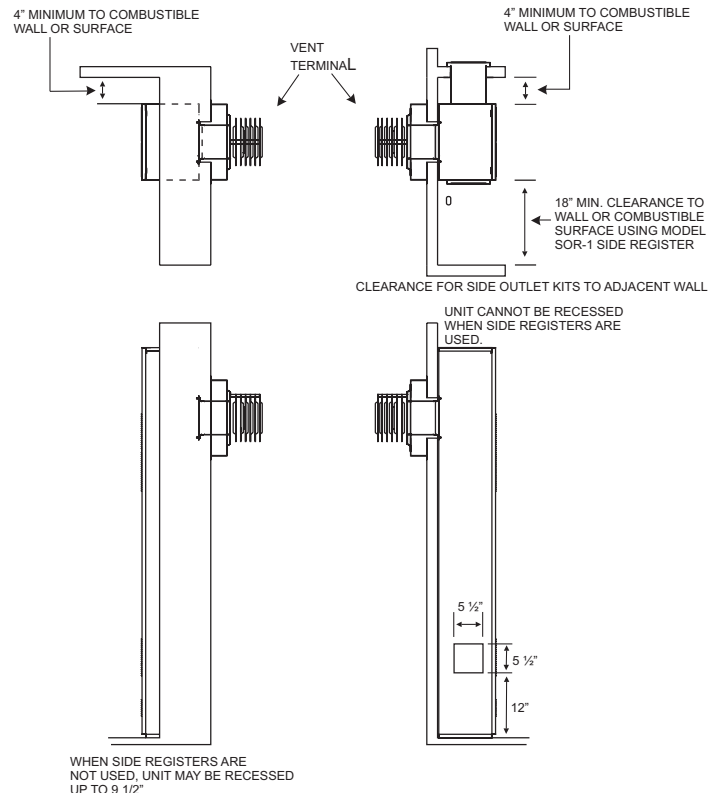
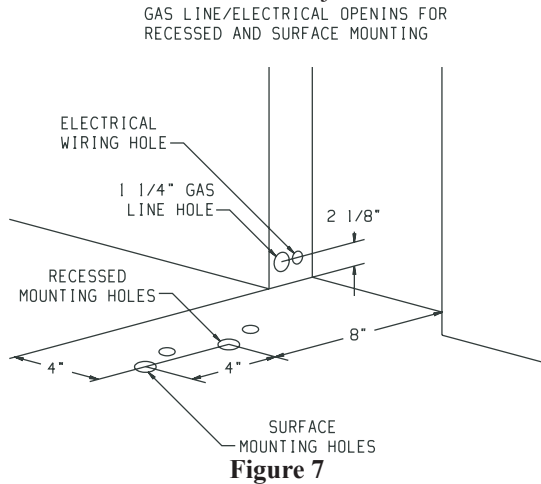

Figure 6

## Locating Electric Supply

A 7/8" (22mm) diameter knockout is provided at the bottom of the left and right side panels. A three-prong (grounding) plug assembly is located within the control compartment (bottom) of the furnace. Please remove 7/8" (22mm) knockout from appropriate side panel when routing plug assembly to an electrical outlet. Unit can be hard wired when recessed. Remove the 3 prong plug assembly and terminate inside the unit junction box.



## Installation of Three-prong (Grounding) Plug Assembly

1. Disconnect nylon cap on 3' (92cm) plug assembly from nylon plug on wiring harness. Remove 3' (92cm) plug assembly from control compartment (bottom) of the furnace.
2. Remove 7/8" (22mm) knockout from appropriate side panel.
3. Insert nylon cap on 3' (92cm) plug assembly into the 7/8" (22mm) hole in the side panel.
4. Connect nylon cap on 3' (92cm) plug assembly to nylon plug on the wiring harness.
5. Place 7/8" (22mm) strain relief bushing around the cord of the 3' (92cm) plug assembly. Insert 7/8" (22mm) strain relief bushing into the 7/8" (22mm) hole in the side panel.

**Attention!** The 7/8" (22mm) strain relief bushing is located within the same envelope as the Installation Instructions and Owner's Manual.

## Attaching Furnace to Wall

Refer to Figure 5 for the location of the 7 1/2" (191mm) diameter wall opening for the furnace. After the wall opening has been located and cut, position flue outlet on furnace in center of wall opening. When attaching furnace to the wall, remove that portion of baseboard and molding on the wall which is behind the furnace. Attach furnace to wall, at the outer casing top, with (2) toggle bolts provided and to floor, at the out casing bottom, with (2) #10 x 1 1/2" (38mm) screws provided.

## Cutting Vent Tubes

This is the most important part of the installation. With the furnace installed on the wall, the 6" (152mm) diameter inlet tube and the 4" (102mm) diameter flue outlet tube are to be marked and cut using the following procedure.

1. Attach 6" (152mm) diameter air inlet tube onto the collar of air drop assembly. Be sure 6" (152mm) diameter air inlet tube is placed as far as possible onto the collar of the air drop assembly. Mark the 6" (152mm) diameter air inlet tube 1/2" (13mm) beyond the outside wall. Remove 6" (152mm)

diameter air inlet tube from collar of air drop assembly.

2. Attach 4" (102mm) diameter flue outlet tube onto flue outlet collar on combustion chamber. Be sure 4" (102mm) diameter flue outlet tube is placed as far as possible onto the collar of flue outlet. Mark the 4" (102mm) diameter flue outlet tube 2 1/4" (57mm) beyond the outside wall. Remove 4" (102mm) diameter flue outlet tube from collar of flue outlet on combustion chamber.
3. Mark or wrap tape completely around the tubes at the marked points to help in making a true cut. Do not crimp or enlarge tubes.

## Installing Vent Assembly (See Figure 8)

1. Place provided caulking beneath the edge of the outside mounting plate. Use additional caulking to correct uneven wall surface, such as clapboard.
2. Attach 6" (152mm) diameter air inlet tube onto the collar of air drop assembly. Attach caulked, outside mounting plate into the 6" (152mm) diameter air inlet tube. Position the outside mounting plate so that 6" (152mm) diameter air inlet tube has a slight downward slope to the outside. **The downward slope is necessary to prevent the entry of rainwater.** Attach outside mounting plate to exterior wall with (4) #10 x 1 1/2" (38mm) screws provided.
3. Apply furnace cement or RTV silicone sealant to 4" (102mm) diameter flue outlet collar on combustion chamber and to 4" (102mm) diameter collar on vent cap. Attach 4" (102mm) diameter flue outlet tube onto flue outlet collar on combustion chamber. Attach vent cap into the 4" (102mm) diameter flue outlet tube. Attach vent cap to outside mounting plate with (3) #10 x 1/2" (13mm) screws provided.
4. Installation is complete.

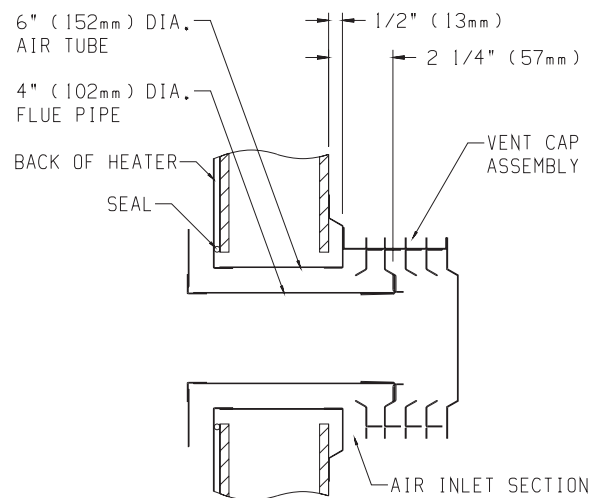

# INSTALLATION INSTRUCTIONS (continued)

## Reassembly and Resealing Vent-Air Intake System

When vent-air intake system is removed for servicing the furnace, the following steps will assure proper reassembly and resealing of the vent-air intake assembly.

1. Remove old caulking beneath the edge of the outside mounting plate. Apply new caulking beneath the edge of the outside mounting plate. Use additional caulking to correct uneven wall surface, such as clapboard.
2. Remove old furnace sealant from flue outlet collar on combustion chamber and collar of vent cap. Remove old furnace sealant from both ends of 4" (102mm) diameter flue outlet tube.
3. Attach 6" (152mm) diameter air inlet tube onto the collar of air drop assembly. Attach caulked, outside mounting plate into the 6" (152mm) diameter air inlet tube. Position the outside mounting plate so that 6" (152mm) diameter air inlet tube has a slight downward slope to the outside. The downward slope is necessary to prevent the entry of rainwater. Attach outside mounting plate to exterior wall with (4) #10 x 1 1/2" (38mm) screws provided.
4. Apply furnace cement or RTV silicone sealant to 4" (102mm) diameter flue outlet collar on combustion chamber and to 4" (102mm) diameter collar on vent cap. Attach 4" (102mm) diameter flue outlet tube onto flue outlet collar on combustion chamber. Attach vent cap into the 4" diameter flue outlet tube. Attach vent cap to outside mounting plate with (3) #10 x 1/2" (13mm) screws provided.
5. Reassembly and resealing vent-air intake system is completed.

## Installing a Vent Near a Window Ledge, Other Type of project or on Siding (vinyl, aluminum, etc.)

Direct vent furnaces are designed to be installed on a uniform outside wall. When the wind comes from any angle (up, down, or from either side), it must hit the vent cap equally over both the air inlet and the flue outlet portions of the vent. Any wall projection, such as a door or window casing, which disturbs the wind on one side of the air inlet section will result in back pressure on the flue section smothering the flame and eventual pilot outage.

When the vent cap is to be installed on siding or it appears that a projection within 6" (152mm) of any side of the air inlet section could shield the air inlet section, the entire vent should be supported away from the wall at least the distance of the projection. 2" x 4" (51mm x 102mm) framing whose outside dimensions match the overall dimensions of the mounting plate is recommended. The 2" x 4" (51mm x 102mm) framing protects siding from possible warpage or discoloration. All joints can then be sealed and painted. The wall depth plus the additional depth of the 2" x 4" (51mm x 102mm) framing should not exceed a total depth of 10" (254mm) for DVC-35 (See Figure 9). If it does, you will need to use the DV-1190 Extended Flue Kit.

Vinyl siding kit, DV-822, is available from Empire Comfort Systems, Inc. The depth is 3" (76mm), which enables the vent cap to be extended away from siding or projections. The wall depth plus the additional 3" (76mm) depth of the vinyl siding vent cap extension should not exceed a total depth of 10" (254mm) for DVC-35 (See Figure 10).

**Warning: When vinyl siding vent kit, DV-822 or 2" x 4" (51mm x 102mm) framing is added to an existing installation (furnace is installed) do not attempt to add sections of pipe to the flue outlet tube or air inlet tube. An air tight seal is required for both tubes. Refer to Parts List, page 20 to order tubes.**

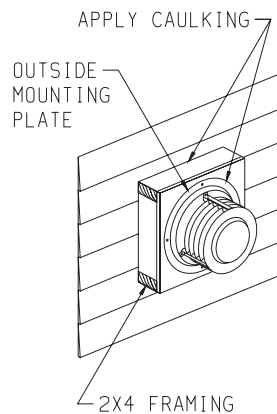

Figure 9

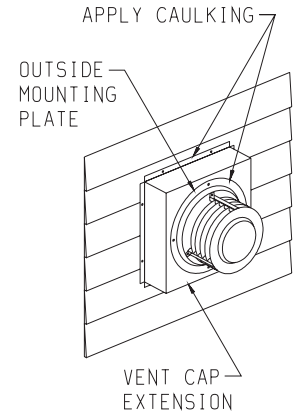

Figure 10

# DVC-35 SPP STANDING PILOT LIGHTING INSTRUCTIONS

## FOR YOUR SAFETY READ BEFORE LIGHTING

**WARNING: If you do not follow these instructions exactly, a fire or explosion may result causing property damage, personal injury or loss of life.**

A. This appliance has a pilot which must be lighted by hand. When lighting the pilot, follow these instructions exactly.

B. **BEFORE LIGHTING** smell all around the appliance area for gas. Be sure to smell next to the floor because some gas is heavier than air and will settle on the floor.

### WHAT TO DO IF YOU SMELL GAS

- Do not try to light any appliance.
- Do not touch any electrical switch; do not use any phone in your building.
- Immediately call your gas supplier from a neighbor's phone. Follow the gas supplier's instructions.

• If you cannot reach your gas supplier, call the fire department.

C. Use only your hand to push in or turn the gas control knob. Never use tools. If the knob will not push in or turn by hand, don't try to repair it; call a qualified service technician. Force or attempted repair may result in a fire or explosion.

D. Do not use this appliance if any part has been under water. Immediately call a qualified service technician to inspect the appliance and to replace any part of the control system and any gas control which has been under water.

## LIGHTING INSTRUCTIONS

1. STOP! Read safety information above.
2. Set the thermostat to lowest setting.
3. Turn off all electric power to the appliance.
4. Remove control access panel (lower front panel).
5. Turn gas control knob clockwise  to "OFF."

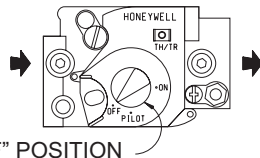

GAS CONTROL KNOB SHOWN IN "OFF" POSITION

6. Wait ten (10) minutes to clear out any gas. Then smell for gas, including near the floor. If you smell gas, STOP! Follow "B" in the safety information above. If you don't smell gas, go to the next step.
7. Remove the pilot access cover located on the combustion chamber.
8. Find pilot - follow metal tube from gas control. The pilot is located between the two burner tubes behind the pilot access cover.

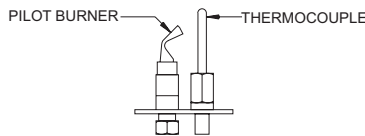

9. Turn gas control knob counterclockwise  to "Pilot."

10. Push and hold red reset button down completely and repeatedly push the ignitor button until the pilot burner is lit. Pilot may also be lit with a match. Continue to hold the red reset button down for about one (1) minute after the pilot is lit. Release button and it will pop back up. Pilot should remain lit. If it goes out, repeat step 5 through 10.

- If button does not pop up when released, stop and immediately call a qualified service technician or gas supplier.
- If the pilot will not stay lit after several tries, turn the gas control knob to "OFF" and call your service technician or gas supplier.

11. Replace pilot access cover.
12. Turn gas control knob counterclockwise  to "ON."
13. Replace control access panel (lower front panel).
14. Turn on all electric power to the appliance.
15. Set thermostat to desired setting.

## TO TURN OFF GAS TO APPLIANCE

1. Set the thermostat to lowest setting.
2. Turn off all electric power to appliance if service is to be performed.
3. Remove control access panel (lower front panel).

4. Push gas control knob slightly and turn clockwise  to "OFF." Do not force.

5. Replace control access panel (lower front panel).

# DVC-35IP INTERMITTENT PILOT LIGHTING INSTRUCTIONS

## FOR YOUR SAFETY READ BEFORE LIGHTING

**WARNING:** If you do not follow these instructions exactly, a fire or explosion may result causing property damage, personal injury or loss of life.

A. This appliance is equipped with an ignition device which automatically lights the pilot.

Do **NOT** try to light the pilot by hand.

B. **BEFORE LIGHTING** smell all around the appliance area for gas. Be sure to smell next to the floor because some gas is heavier than air and will settle on the floor.

### WHAT TO DO IF YOU SMELL GAS

- Do not try to light any appliance.
- Do not touch any electrical switch; do not use any phone in your building.
- Immediately call your gas supplier from a neighbor's phone, Follow the gas supplier's instructions.

- If you cannot reach your gas supplier, call the fire department.

C. Use only your hand to push in or turn the gas control knob. Never use tools. If the knob will not push in or turn by hand, don't try to repair it; call a qualified service technician. Force or attempted repair may result in a fire or explosion.

D. Do not use this appliance if any part has been under water. Immediately call a qualified service technician to inspect the appliance and to replace any part of the control system and any gas control which has been under water.

## OPERATING INSTRUCTIONS

1. **STOP!** Read safety information above.
2. Set the thermostat to lowest setting.
3. Turn off all electric power to the appliance.
4. This appliance is equipped with an ignition device which automatically lights the pilot. Do **not** try to light the pilot by hand.

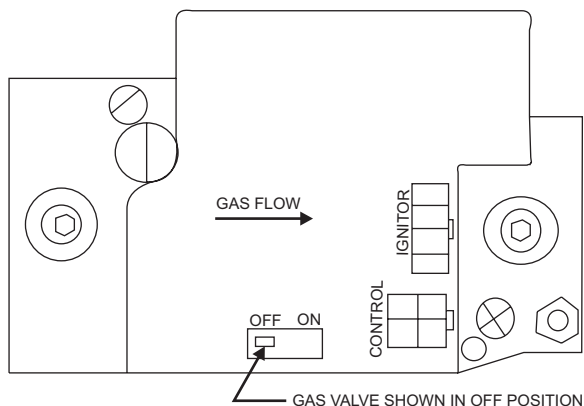

HONEYWELL IP SMART VALVE

5. Remove front panel door.
6. Slide gas control switch to "OFF."
7. Wait ten (10) minutes to clear out any gas. Then smell for gas, including near the floor. If you smell gas, **STOP!** Follow "B" in the safety information above. If you don't smell gas, go to the next step.
8. Slide gas control switch to "ON."
9. Replace front panel door.
10. Turn on all electric power to the appliance.
11. Set thermostat to desired setting.
12. If the appliance will not operate, follow the instructions, "TO TURN OFF GAS TO APPLIANCE" and call your service technician or gas supplier.

## TO TURN OFF GAS TO APPLIANCE

1. Set the thermostat to lowest setting.
2. Turn off all electric power to the appliance if service is to be performed.
3. Remove front panel door.
4. Slide gas control switch to "OFF."
5. Replace front panel door.



# PILOT FLAME CHARACTERISTICS

The correct pilot flame (Figure 11) will be blue, extending past the thermocouple. The flame will surround the thermocouple just below the tip.

Natural gas pilots require adjusting when the inlet gas pressure is above 5" w.c. (1.245kPa). Remove the pilot cover screw on the control valve (Figure 3), and turn the adjustment screw clockwise to reduce flame. Replace pilot cover screw to eliminate gas leaking at that control valve opening.

LP gas (Propane) will not require adjustment.

After use, cleaning may be required for the proper flame.

## IP-Model Pilot



This heater is using a Honeywell "Smart Valve" system for intermittent pilot ignition.

On a call for heat by the thermostat, this control turns on a 24 volt mini hot surface ignitor which lights a pilot that in turn lights the main burner. The gas valve used in this system is a step opening which opens at a lower pressure for ignition and then steps to a full inlet pressure of 4" H<sub>2</sub>O pressure on Natural gas and 10" H<sub>2</sub>O pressure on LP gas.

## Pilot Flame Adjustment

The pilot flame should envelop 3/8 to 1/2 inch (10 to 13mm) of the tip of the flame rod. See Figure 11.

To adjust:

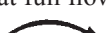
1. Remove the pilot adjustment cover screw.
2. Turn the inner adjustment screw clockwise  to decrease or counterclockwise  to increase pilot flame. Pilot adjustment is shipped at full flow rate. Turn the inner adjustment screw clockwise  if the inlet pressure is too high.
3. Replace the cover screw after the adjustment to prevent gas leakage.

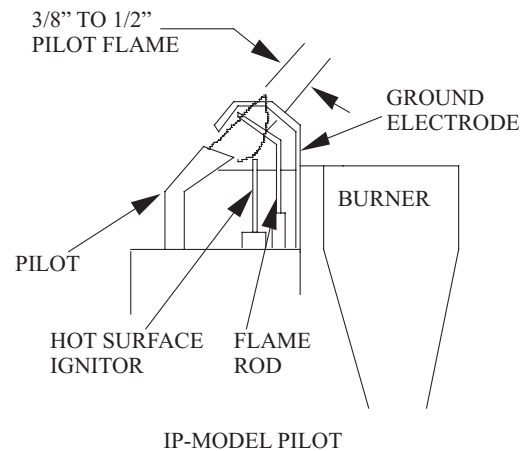
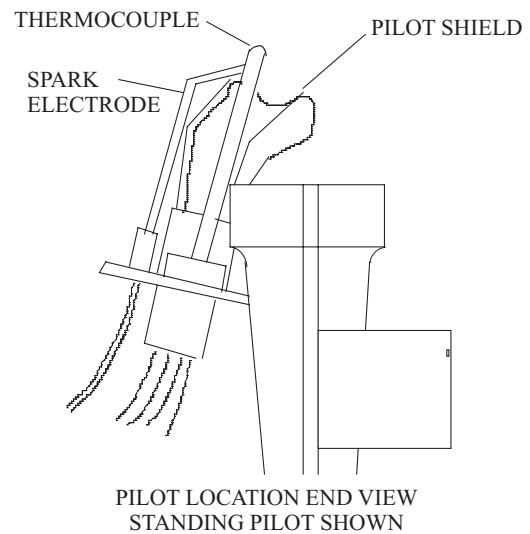
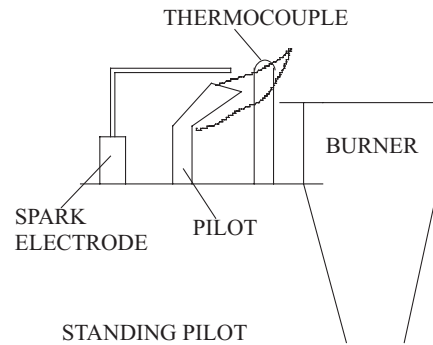

**Figure 11**



# MAIN BURNER FLAME CHARACTERISTICS

The correct flame will be a short, blue inner flame with a much larger, light blue, outer flame. The burner does not have a primary air adjustment. The flame will be correct if the factory-set pressure and orifice opening are used. After the furnace has been operating, the burner ports may be blocked by foreign matter carried in by combustion air. Therefore, cleaning of the burner may be needed for proper flame.

The clean burner port disconnect the gas supply to the valve, and remove the screws fastening the burner. After removing the burner door from the burner box, remove each main burner. Pilot mounting bracket will need to be unscrewed and moved out the way to remove all burners. Burners can be blown out using compressed air or by blowing through them. Be sure there is no lint or foreign debris blocking the burner ports. Reassemble using the same screws earlier removed and locate pilot in the same position as before and noted above.

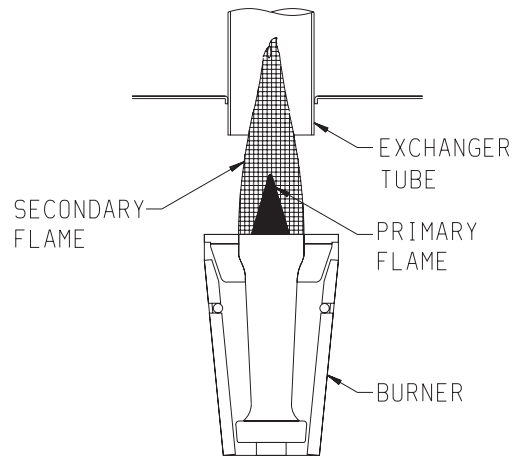

Figure 12

## WIRING

The appliance, when installed, must be electrically grounded in accordance with local codes or, in the absence of local codes, with the *National Electrical Code, ANSI/NFPA 70* or *Canadian Electrical Code, CSA C22.1*, if an external electrical source is utilized. **This appliance is equipped with three-prong (grounding) plug for your protection against shock hazard and should be plugged directly into a properly grounded three-prong receptacle. Do not cut or remove the grounding prong from this plug.** For an ungrounded receptacle, an adapter, which has two prongs and a wire for grounding, can be purchased, plugged into the ungrounded receptacle and its wire connected to the receptacle mounting screw. With this wire completing the ground, the appliance cord plug can be plugged into the adapter and be electrically grounded. A 7/8" hole is provided in the junction box for use with a conduit connector if local codes require this type of protection.

### Thermostat Installation

The thermostat should be installed in the same room as the furnace 4' to 5' above the floor and away from another heat source (cooking stove, hot water heater, etc.) including walls and doorways with a heat source in an adjoining room. **Do Not Install Thermostat on Outside Wall.**

**CAUTION:** Label all wires prior to disconnection when servicing controls. Wiring errors can cause improper and dangerous operation. Verify proper operation after servicing.

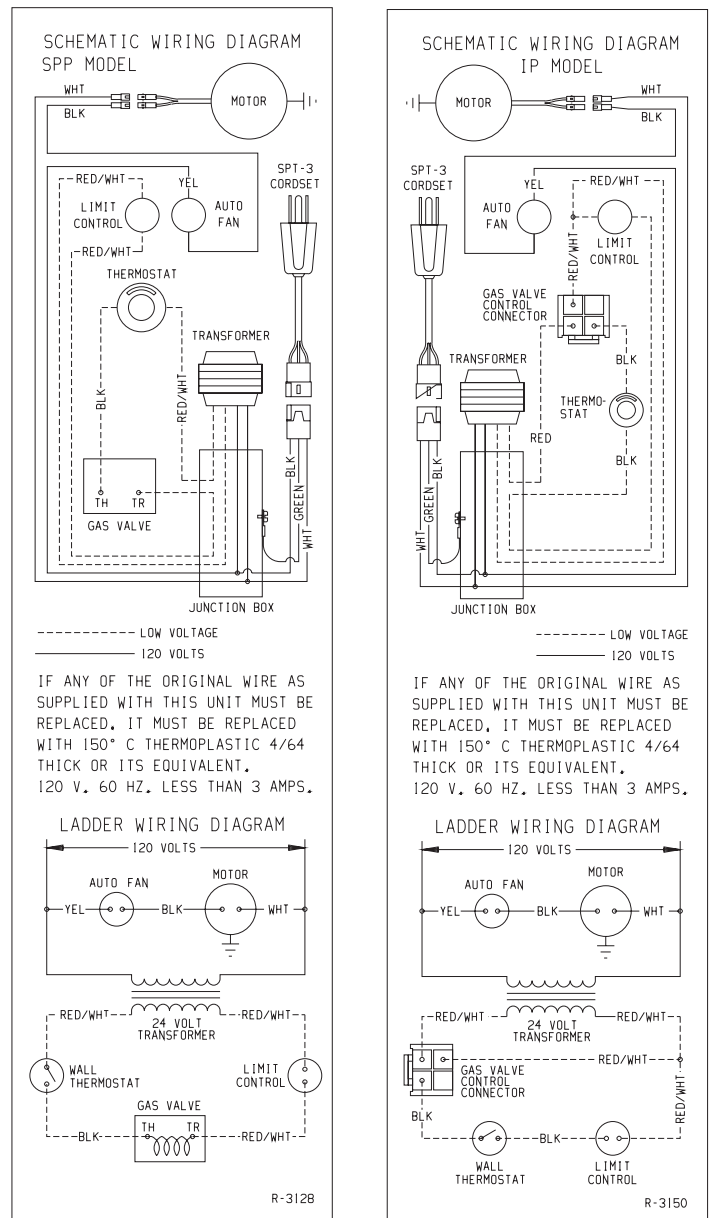
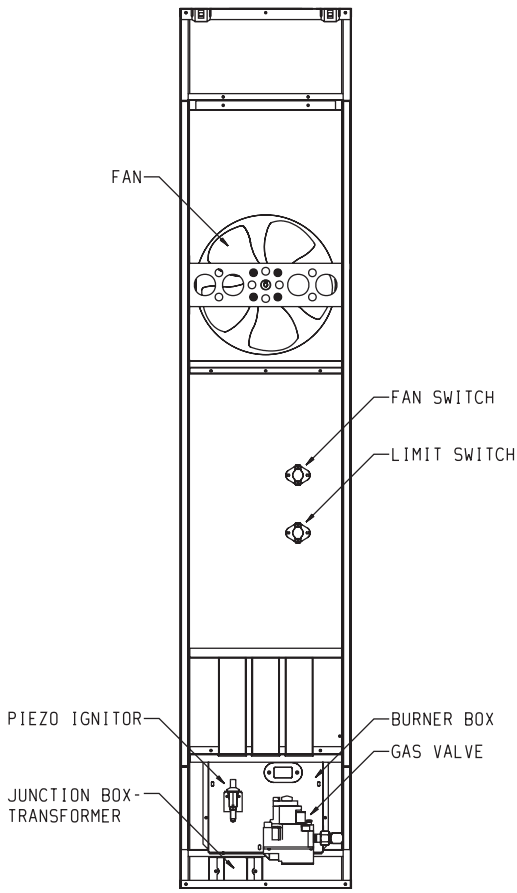
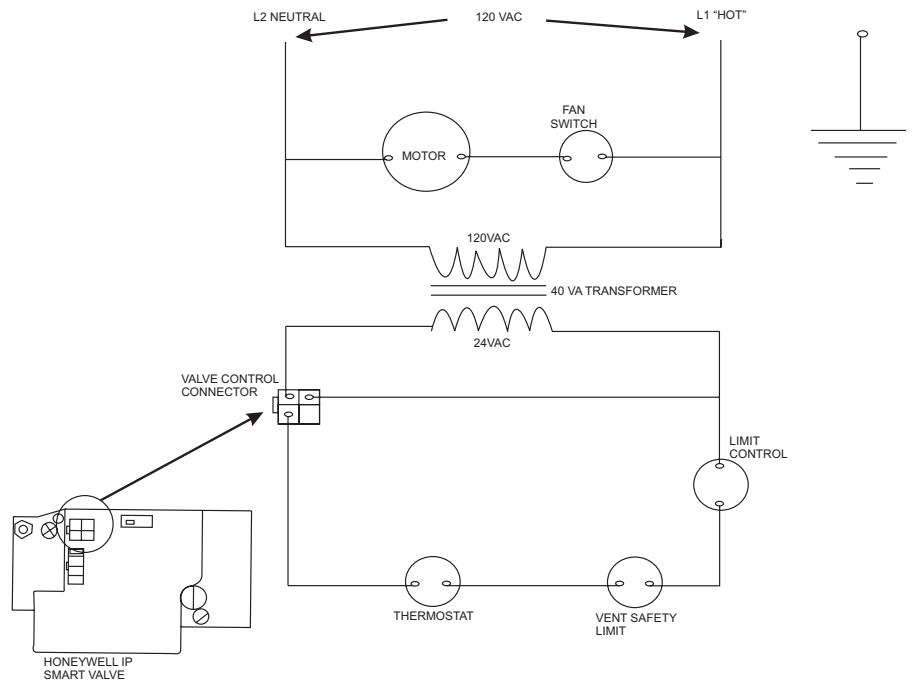
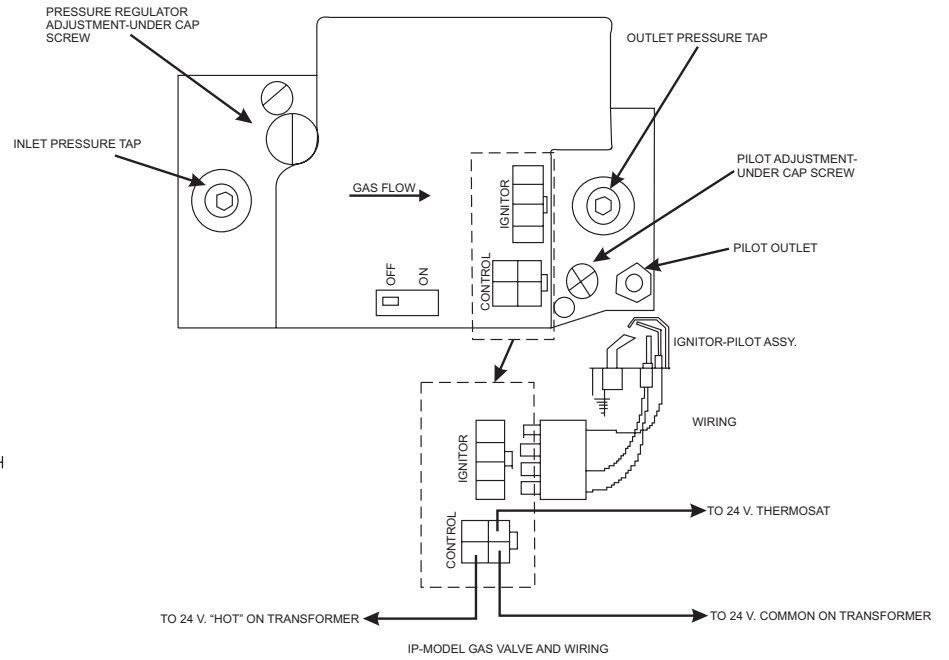

Figure 13



**Figure 14**



**LADDER WIRING DIAGRAM**

**Figure 15**

# SERVICE AND MAINTENANCE SUGGESTIONS

**GENERAL:** All furnaces have been fire-tested to check for proper operation. This includes, main burner flame, pilot flame, fan operation, fan control, limit control and automatic valve operation. If the furnace fails to function on initial installation, it is advisable to re-check the following:

1. 115 volts to the junction box.
2. Inlet gas pressure.
3. The 24 volt system.
4. Type of gas being used and that shown on the rating label.

The Service Department at Empire Comfort Systems, Inc. may be contacted to assist in servicing furnace.

## **Standing Pilot Model**

**Servicing the Pilot and Main Burners, Pilot Orifice, Thermocouple, and Main Burner Orifices:** Disconnect the gas supply at the inlet to the control valve. Then remove the burner door to gain access to the above listed components.

**Spark Igniter Does Not Light Pilot:** With air in the gas line, such as when the furnace is first installed or was off all summer, the pilot flame may be too lean to ignite on the first few trials. Turn the control valve knob to pilot position and depress the red reset button. Holding the button down continually to bleed the line;

1. Use lighter rod to light pilot with a match
2. Use the piezo ignitor at 30 second intervals until it lights.

## **If Electrode Does Not Produce Spark:**

1. Check wire connections.
2. Check gap for pilot burner to the electrode tip. Should be between 1/8" (3mm) and 3/16" (4.8mm). Electrode wire and tip must be more than 1/4" (6.3mm) away from all other metal components.

## **If Pilot Does Not Light By Any Means:**

1. Check valve knob for being in the "Pilot" position.
2. Check pilot adjustment for being full open (counterclockwise to open).
3. If gas is available in the supply tubing, the pilot orifice and/or pilot burner is probably restricted by a spider web. Clean pilot assembly and relight.

## **If Pilot Does Not Remain On After Releasing Knob:**

1. Follow instructions and hold button down longer and harder.
2. Determine if pilot flame extends past thermocouple; if not, adjust input or clean pilot burner.
3. Replace thermocouple if millivolts read less than 15 millivolts.

## **Pilot Outage During Normal Operation:**

1. Check air inlet tube for a good tight fit at both ends (6" diameter tube).
2. Check burner door and pilot hole cover for tight seal.
3. Check input by manifold pressure gauge or gas meter.

## **Main Gas Valve Does Not Open when Thermostat Is Turned To On:**

1. Check for 24 volts to valve by removing one wire and touching to the **SAME TERMINAL** it was on. Terminal should have a light spark. **DO NOT SHORT ACROSS TERMINALS, AS IT WILL BURN OUT THE WALL THERMOSTAT.**
2. Thermostat wires at the wall may be shorted, so check for a faulty thermostat.
3. To check for line voltage to furnace, remove front panel and short across two-terminal fan control to allow fan to operate (Figure 14).

## **Cleaning Combustion (Exchanger) Assembly**

A QUALIFIED SERVICE PERSON should remove the combustion (exchanger) assembly and flue baffles. Apply air pressure to the inside of the combustion (exchanger) assembly and flue baffles in order to clear all passageways.

## **Oiling the Motor**

The Fan motor should be cleaned and oiled once each heating season. Oil holes are located on the top at each end of the motor. Use a few drops of #10 motor oil. To clean the motor, blow air through its ventilation openings with a vacuum cleaner or low pressure air source.

# DVC-35IP INTERMITTENT PILOT SEQUENCE OF OPERATION

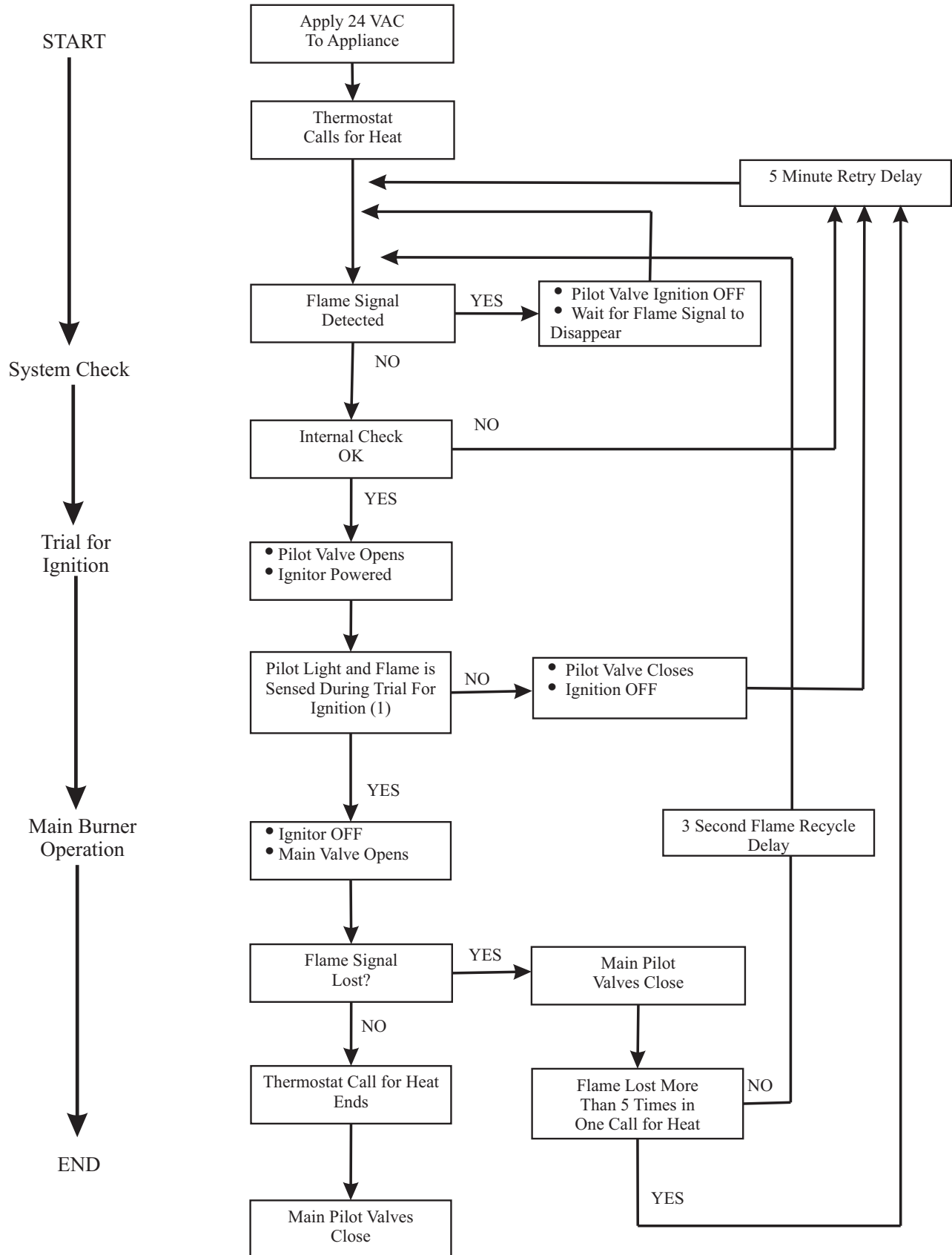

(1) Ignitor will turn OFF about 30 seconds into the trial for ignition if the pilot flame has not lit. It will turn back ON for the final 30 seconds of the 90 second trial for ignition. The pilot will be energized during the entire trial for ignition. This is normal operation for this gas ignition system.

# DVC-35IP INTERMITTENT PILOT SYSTEM TROUBLESHOOTING SEQUENCE

START

## IP SYSTEM TROUBLESHOOTING SEQUENCE

SmartValve™ System Troubleshooting Sequence  
 Note: Before Troubleshooting, Become Familiar with the Sequence of Operation

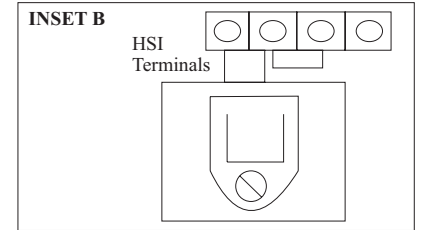
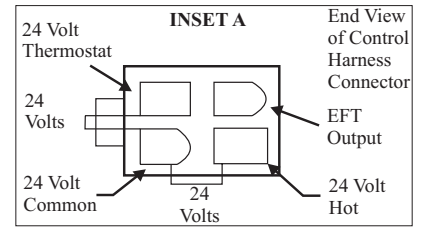

Turn OFF Gas Supply  
 Disconnect System Control Harness  
 Set Thermostat to Call for Heat

Check for Proper Voltage at Control Harness (See Inset A - Voltage Should be 24V Between Thermostat and 24V Common, and 24V Between 24V Common and 24V Hot.)

NO

Check  
 Line Voltage Power  
 Low Voltage Transformer  
 Limit Controller  
 Thermostat  
 Wiring

YES

Plug Harness into SmartValve Control  
 Wait for Internal Check Delay (SV9501)

Igniter Warms UP and Glows Red

NO

Unplug Pilot Burner Cable.  
 Measure Voltage at SmartValve HSI Element Output (See Inset B) 24V Nominal

NO

Replace SmartValve Control

Note: Igniter Will Cycle OFF and Back ON Once During the 90 Second Ignition Trial

Replace Igniter/Flame Rod Assembly

Reconnect Pilot Burner Cable

Reconnect Pilot Burner Cable

YES

Turn On Gas Supply  
 Pilot Burner Lights

NO

Check that Pilot Gas is Flowing  
 Wait to Assure Pilot Gas Tubing is Purged.

NO

Replace SmartValve Control

YES

Measure Voltage Between 24V Hot and 24V Common Leads to SmartValve Control. Must Measure at Least 19.5 VAC with Igniter Powered. See Inset A to Identify Proper Lead. This Check Must be Done with the SmartValve Control Connected and Igniter Powered.

NO

Check Transformer and Line Volt Supply

Replace Igniter/Flame Rod Assembly

Main Valve Opens and Main Burner Lights

NO

Check that Pilot Flame Makes Good Contact with Pilot Burner Flame Rod  
 Check for Good Electrical Connection Through the Pilot Tubing  
 If Both of the Above are Good, Replace Igniter/Flame Rod

YES

Cycle Thermostat OFF and Back ON

System is Okay

Main Burner Lights

NO

Replace SmartValve Control

# HOW TO ORDER REPAIR PARTS

Parts can be ordered only through your service person or dealer. For best results, the service person or dealer should order parts through the distributor. Parts can be shipped directly to the service person/dealer.

All parts listed in the Parts List have a Part Number. When ordering parts, first obtain the Model Number from the name plate on your equipment. Then determine the Part Number (not the Index Number) and the Description of each part from the following appropriate illustration and list. Be sure to give all this information...

Furnace Model Number \_\_\_\_\_ Part Description \_\_\_\_\_

Furnace Serial Number \_\_\_\_\_ Part Number \_\_\_\_\_

Type of Gas (Propane or Natural) \_\_\_\_\_

Do not order bolts, screws, washers or nuts. They are standard hardware items and can be purchased at any local hardware store. Shipments contingent upon strikes, fires and all causes beyond our control.

**Empire Comfort Systems, Inc.** Nine Eighteen Freeburg Ave. Belleville, IL 62222-0529

## PARTS LIST

**PLEASE NOTE:** When ordering parts, it is very important that **part number** and **description** of part coincide.

INDEX NO.	PART NUMBER	DESCRIPTION	INDEX NO.	PART NUMBER	DESCRIPTION
1	DV-1213	TOP PLATE	34	DV-781	OBSERVATION HOLE COVER WITH MICA
2	R-3165	DOOR CLIP (2 REQUIRED)	35	M-155	GASKET - OBS HOLE
3	DV-1204	CASING SIDE - RIGHT	36	FF-160	PIEZO BRACKET (SPP ONLY)
4	DV-1202	CASING BACK	37	DV-1240	BURNER COMPARTMENT FRONT
5	DV-1205	CASING SIDE - LEFT	38	DV-12655	BURNER COMPARTMENT BODY
6	DV-1249	AIR DROP	39	712059	GASKET - TUBE SEAL
7	DV-1230	TURBULATOR (3 REQUIRED)	40	DV-775	SEAL BRACKET (SPP ONLY)
8	DV-1233	OUTLET BOX REAR	40	DV-691	SEAL BRACKET (IP ONLY)
9	DV-1224	OUTLET BOX COVER	41	M-156	MANIFOLD GASKET
10	R-3161	FAN BLADE	42	DV-1235	PILOT BRACKET (IP ONLY)
11	R-3166	FAN MOTOR	43	R-3031	BURNER (3 REQUIRED)
12	DV-1246	MOTOR MOUNTING BRACKET	44	DV-1239	BURNER BRACKET
13	R-1536	BUSHING	45	UH-810	TRANSFORMER MOUNTING BRACKET (SPP ONLY)
14	R-1499	RUBBER GROMMET (4 REQUIRED)	45	UH-452	TRANSFORMER MOUNTING BRACKET (IP ONLY)
15	R-1454	BRASS BUSHING (4 REQUIRED)	46	R-1995	TRANSFORMER (SPP ONLY)
16	R-3164	DOOR CLIP (2 REQUIRED)	46	R-998	TRANSFORMER (IP ONLY)
17	DV-1251	INNER SHIELD - RIGHT (INCLUDES NO. 22)	47	UH-451	JUNCTION BOX COVER
18	R-6176	FAN CONTROL SWITCH	48	DV-572	JUNCTION BOX
19	R-3175	LIMIT SWITCH	49	R-1410	BUSHING
20	DV-1255	INNER SHIELD FRONT (USA)	50	R-690	CORD SET
20	15666	INNER FRONT ASSEMBLY (CANADA)	51	R-1515	BUSHING
21	DV-1253	INNER SHIELD COVER PLATE (2 REQUIRED)	52	DV-1215	BOTTOM PLATE
22	DV-1252	INNER SHIELD - LEFT (INCLUDES NO. 22)	53	R-3034	PILOT - NAT (SPP ONLY)
23	DV-1257	EXCHANGER ASSEMBLY	53	R-3035	PILOT - LPG (SPP ONLY)
24	R-3162	FILTER	54	GWT-021	PILOT BRACKET (SPP ONLY)
25	R-3163	FILTER RETAINER	55	R-3180	ELECTRODE AND WIRE (SPP ONLY)
26	R-3232	PILOT - NAT (IP ONLY)	56	R-2256	THERMOCOUPLE - 18" (SPP ONLY)
26	R-3233	PILOT - LPG (IP ONLY)	57	R-6389	WALL THERMOSTAT - 24 VOLT
27	P-88-61	ORIFICE - NAT (3 REQUIRED)	58	DV-1273	VENT KIT COMPLETE
27	P-88-61C	ORIFICE - LPG (3 REQUIRED)	59	DV-1355	FLUE OUTLET TUBE
28	DV-1236	MANIFOLD	60	DV-1354	AIR INLET TUBE
29	DV-1259	FRONT PANEL	61	DV-131	OUTSIDE MOUNTING PLATE
30	P-112	MANIFOLD UNION	62	DV-769	VENT CAP
31	R-1109	BUSHING (3/8 X 1/2)	NOT SHOWN	DV-1261	PILOT TUBING
31	R-9502	BUSHING (3/8 X 3/4) - NAT (IP ONLY)	NOT SHOWN	R-1081	PILOT ORIFICE - NAT (SPP ONLY)
32	R-3170	GAS VALVE - NAT (IP ONLY)	NOT SHOWN	R-1089	PILOT ORIFICE - LPG (SPP ONLY)
32	R-3171	GAS VALVE - LPG (IP ONLY)	NOT SHOWN	R-1233	PILOT ORIFICE - NAT (IP ONLY)
32	R-2148	GAS VALVE - NAT (SSP ONLY)	NOT SHOWN	R-3265	PILOT ORIFICE - LPG (IP ONLY)
32	R-5655	GAS VALVE - LPG (SPP ONLY)	NOT SHOWN	R-3172	WIRE HARNESS (SPP ONLY)
33	R-2708	PIEZO IGNITOR (SPP ONLY)	NOT SHOWN	R-3173	WIRE HARNESS (IP ONLY)
			NOT SHOWN	R-3236	WIRE (IP ONLY)

USE ONLY MANUFACTURER'S REPLACEMENT PARTS. USE OF ANY OTHER PARTS COULD CAUSE INJURY OR DEATH.



# PARTS VIEW

DVC-35 IP  
DVC-35 SPP

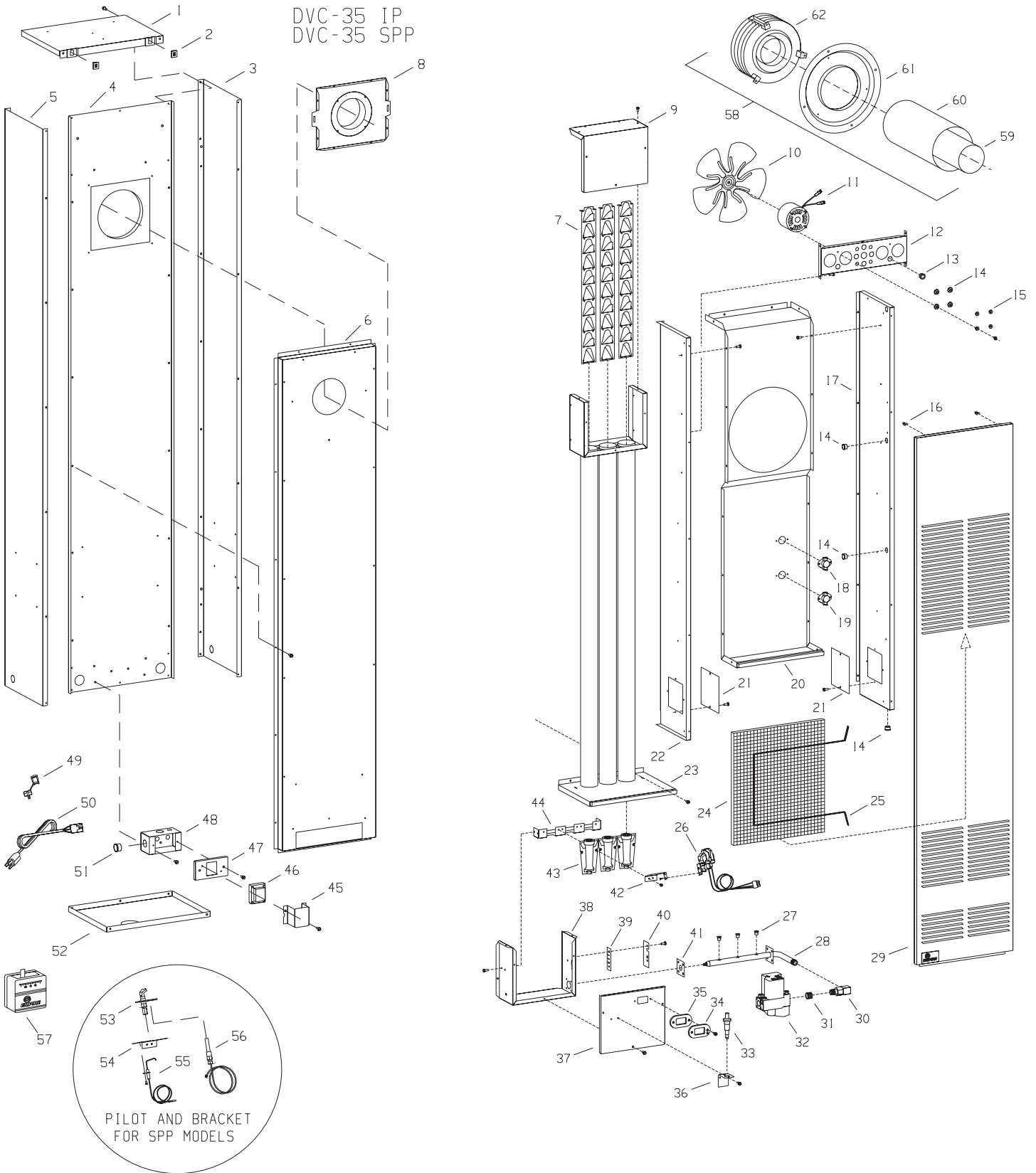







Empire Comfort Systems

Empire Comfort Systems, Inc.  
918 Freeburg Ave. Belleville, IL 62220  
PH: 618-233-7420 or 800-851-3153  
FAX: 618-233-7097 or 800-443-8648  
info@empirecomfort.com

[www.empirecomfort.com](http://www.empirecomfort.com)